

TECHNICAL DRAWING REFERENCE

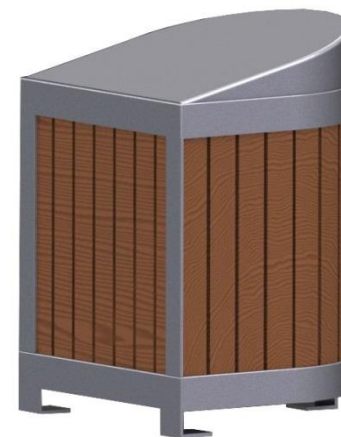
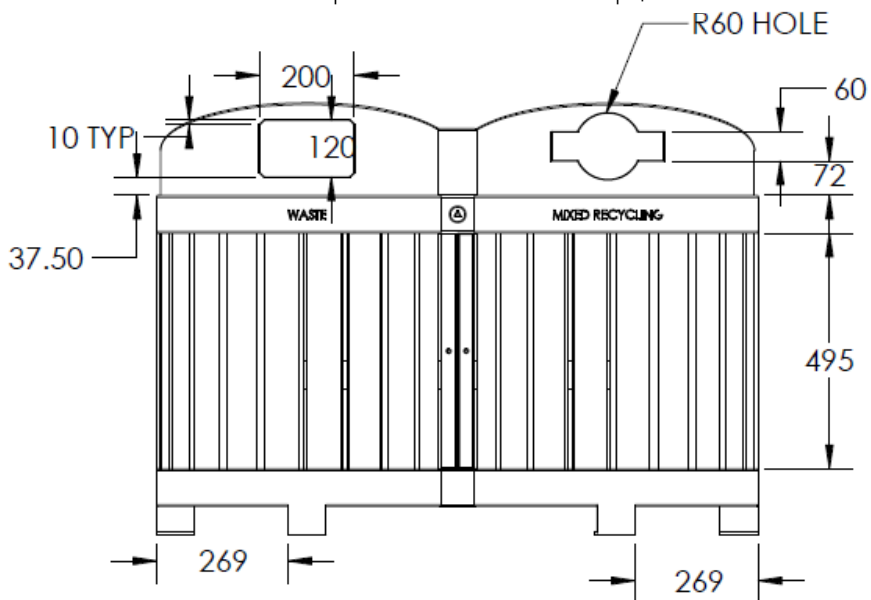
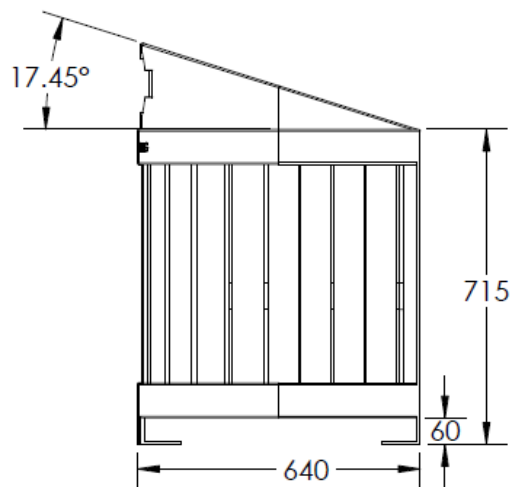

MATERIAL SPECIFICATIONS

Carbon steel, Recycled plastic wood planks, galvanized steel inside liners, #304 Stainless steel hardware.

RAL Standard Colours: 

**Final product design may not be exactly as shown.

