

TECHNICAL DRAWING REFERENCE

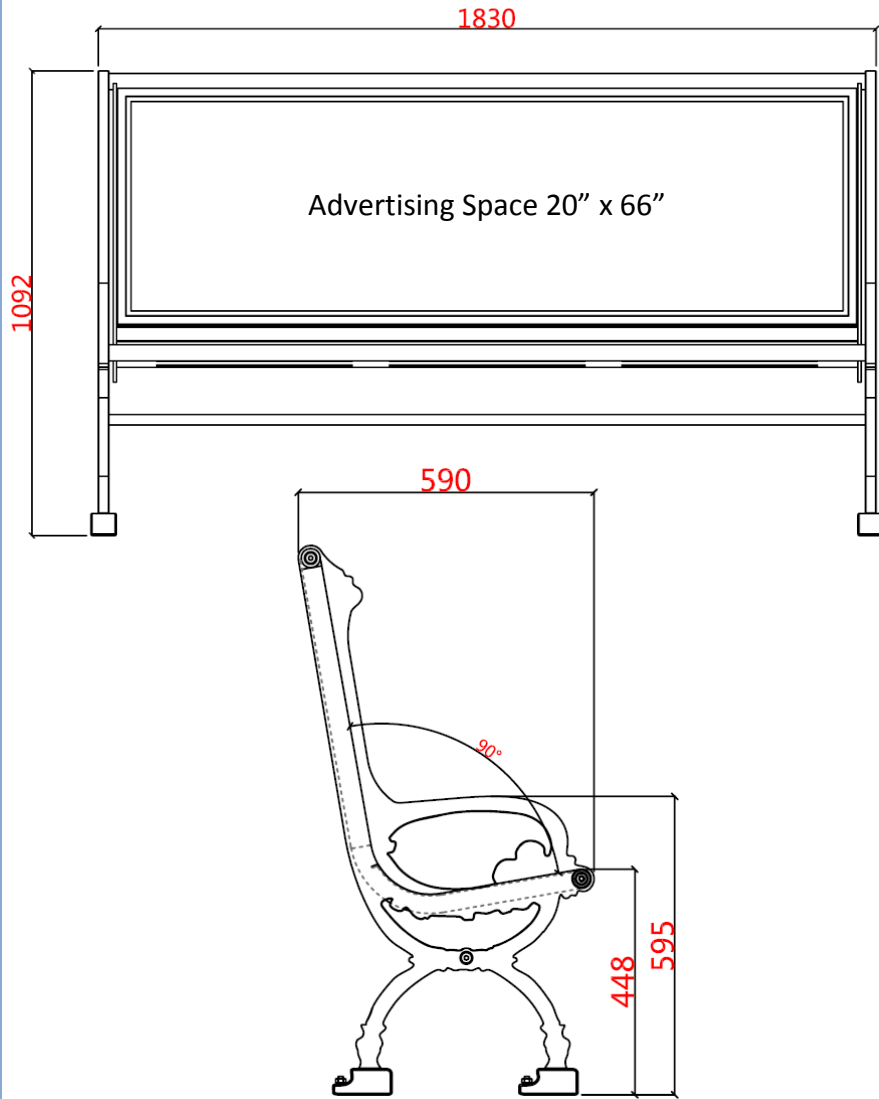

MATERIAL SPECIFICATIONS

Carbon steel construction, Casting bench ends, Plexiglas sign board,  
 Polyester powder coated, #304 Stainless steel hardware.

RAL Standard Colours: 

\*\*Final product design may not be exactly as shown.

