

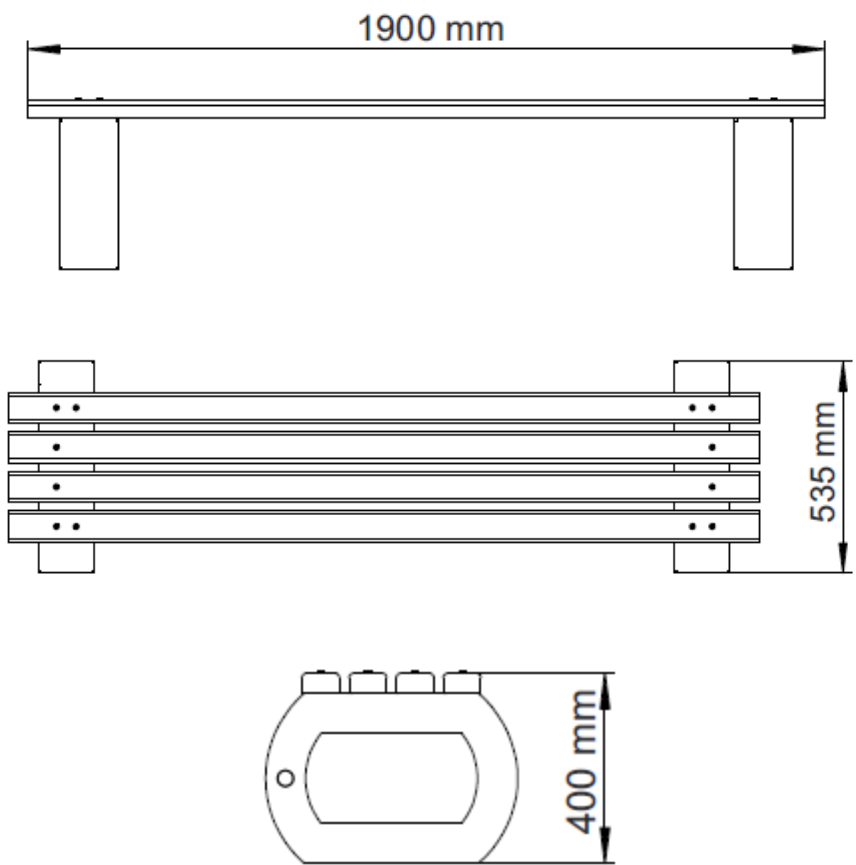

POLAR SITE FURNISHINGS
 12-111 Fourth Ave. Unit 120
 St. Catharines, ON,
 Canada L2S3P5
 Ph: 905-397-5353
 E: pnolan@sitefurnishings.net
 URL: www.sitefurnishings.net

RING BENCH		SPECIFICATION DATASHEET	
PRE-CAST CONCRETE. RECYCLED PLASTIC WOOD. CARBON STEEL SUPPORTS			
LENGTH: 75.2" (191 cm)	DEPTH: 21.25" (54 cm)	HEIGHT: 15.75" (40 cm)	
MOUNTING: Free Standing		FINISH: Natural Stone / RPL wood	
SEAT HEIGHT: 15.75" (40 cm)		WEIGHT: 176 lbs. (80 kgs) 	



MATERIAL SPECIFICATIONS

Carbon steel construction, Pre-cast concrete bench ends, exposed aggregate with UV and water resistant varnish, Recycled plastic wood boards, Stainless steel hardware.

- Standard Pre-cast Colours: Brown, Grey, White, Speckled
- RAL Standard Colours: 

*Final design may not be exactly as shown.