

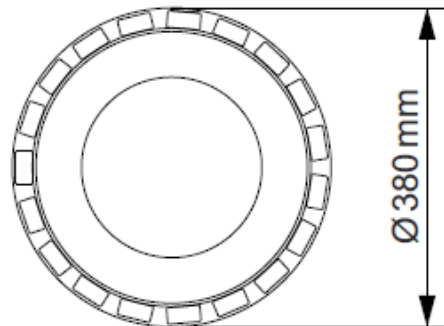

POLAR SITE FURNISHINGS
 12-111 Fourth Ave. Unit 120
 St. Catharines, ON,
 Canada L2S3P5
 Ph: 905-397-5353
 E: pnolan@sitefurnishings.net
 URL: www.sitefurnishings.net

RANIER RECEPTACLE	SPECIFICATION DATASHEET	
PRE-CAST CONCRETE. MILD STEEL		
DIAMETER: 15" (38cm)	HEIGHT: 23.6" (60cm)	
MOUNTING: Free Standing	FINISH: Natural Stone / Powder Coating	
CAPACITY: 9.25 gal. (35 litres)	WEIGHT: 93 lbs. (42 kgs)	

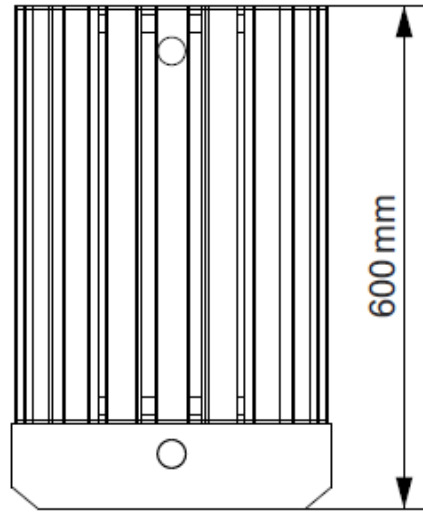

MATERIAL SPECIFICATIONS

Pre-cast steel re-enforced concrete, Galvanized vertical metal slats, Spun metal powder coated mild steel lid with ash urn, Galvanized inside liner.

Standard Pre-cast Colours: Brown, Grey, White, Speckled

RAL Standard Colours: ● ● ● ● ● ● ● ● ● ●

*Final design may not be exactly as shown.