

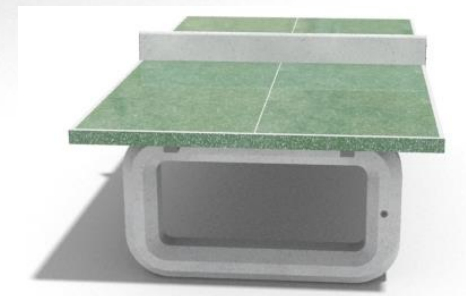

POLAR SITE FURNISHINGS  
 12-111 Fourth Ave. Unit 120  
 St. Catharines, ON, Canada  
 L2S3P5  
 Ph: 905-397-5353  
 Email: pnolan@polarsf.com  
 URL: www.sitefurnishings.net

<b>PING PONG TABLE</b>		<b>TECHNICAL DRAWING</b>
PRECAST AGGREGATE CONSTRUCTION		
LENGTH: 107" (274cm)	WIDTH: 60" (153cm)	TABLE HEIGHT: 30" (76cm)
MOUNTING: Free Standing	FINISH: Natural Aggregate	WGT: 2160lbs. (980kgs) 

TECHNICAL DRAWING REFERENCE

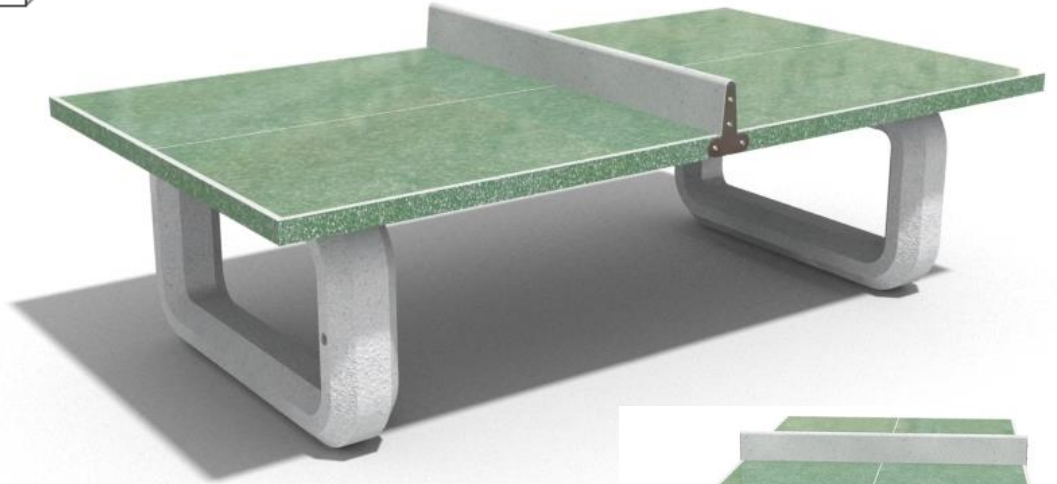
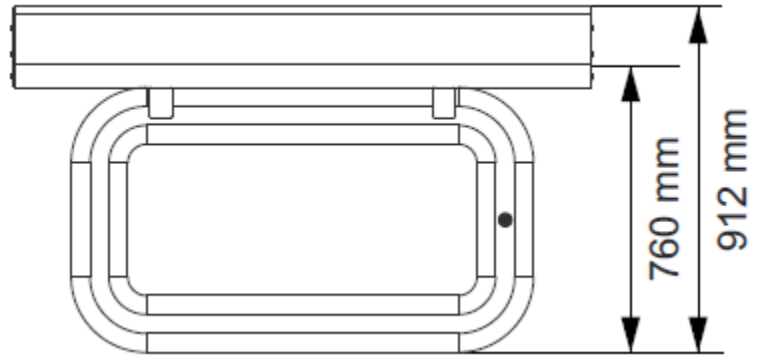
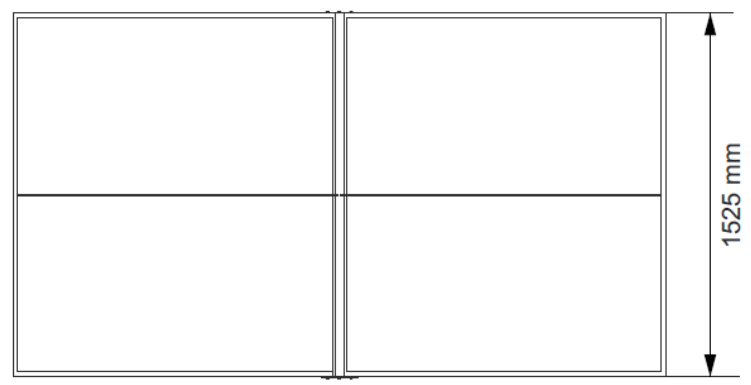
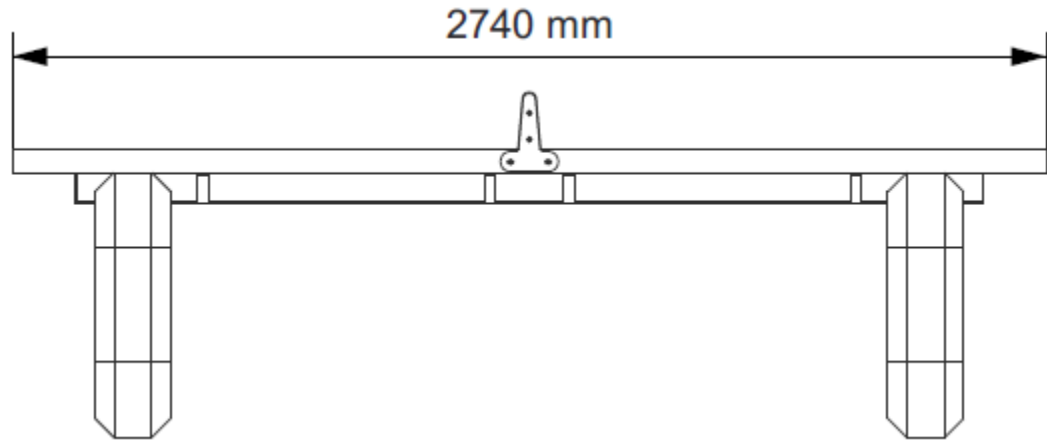

MATERIAL SPECIFICATIONS

Heavy-duty steel reinforced concrete, 2 polished precast table tops & net, exposed aggregate with UV and water resistant varnish, Stainless steel hardware.

RAL Standard Colours: 

\*\*Final product design may not be exactly as shown.