

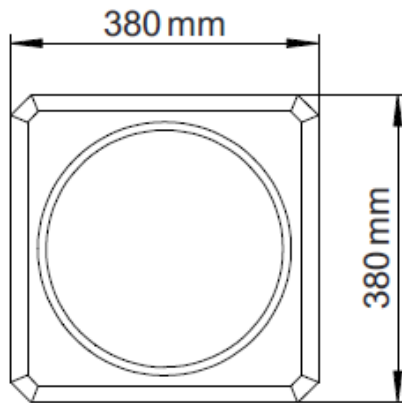

POLAR SITE FURNISHINGS  
 12-111 Fourth Ave. Unit 120  
 St. Catharines, ON,  
 Canada L2S3P5  
 Ph: 905-397-5353  
 E: pnolan@sitefurnishings.net  
 URL: www.sitefurnishings.net

<b>LAKESIDE RECEPTACLE</b>		<b>SPECIFICATION DATASHEET</b>
PRE-CAST STEEL RE-ENFORCED CONCRETE. MILD STEEL. STAINLESS STEEL		
LENGTH: 15" 38cm	WIDTH: 15" 38 cm	HEIGHT: 24.4" (62 cm)
MOUNTING: Free Standing		FINISH: Natural Stone / Powder Coating
CAPACITY: 8 gal. (30 litres)		WEIGHT: 253 lbs. (115 kgs) 

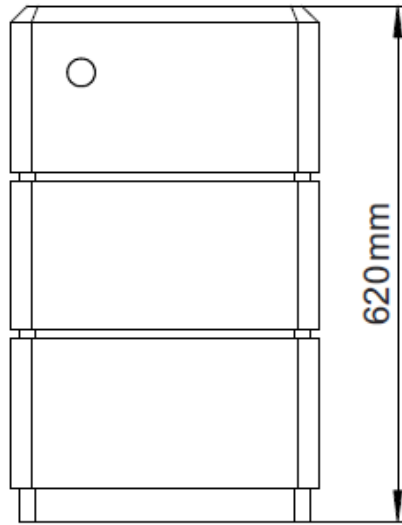

**MATERIAL SPECIFICATIONS**

Pre-cast steel re-enforced concrete, Spun stainless steel powder coated lid, Inset ash urn, Galvanized inside liner.

Standard Pre-cast Colours: Brown, Grey, White, Speckled

RAL Standard Colours: 

\*Final design may not be exactly as shown.