



POLAR SITE FURNISHINGS
12-111 Fourth Ave. Unit 120
St. Catharines, ON, Canada
L2S3P5
Ph: 905-397-5353
Email: pnolan@polarsf.com
URL: www.sitefurnishings.net

DC15.51 RING BIKE RACK

TECHNICAL DATASHEET

CARBON STEEL CONSTRUCTION

LENGTH: 27.6"

WIDTH: 5.2"

HEIGHT (Above ground): 35.4"

MOUNTING: Flange surface

FINISH: E- Coating | Powder Coating

TECHNICAL DRAWING REFERENCE

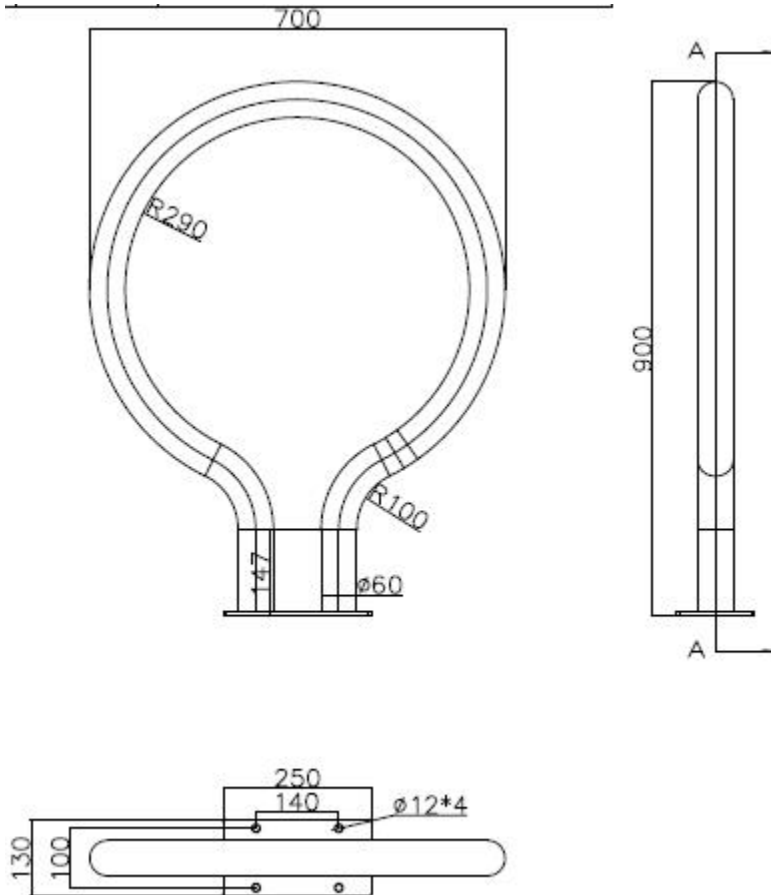

Φ 60mm pipe



MATERIAL SPECIFICATIONS

Carbon steel construction, E-coating | Polyester powder coating finish,
304 stainless steel anchoring hardware.

RAL Standard Colours:

**Final product design may not be exactly as shown.

