



POLAR SITE FURNISHINGS
 12-111 Fourth Ave. Unit 120
 St. Catharines, ON, Canada
 Postal Code: L2S3P5
 Ph: 905-397-5353
 Email: pnolan@polarsf.com
 URL: www.sitefurnishings.net

WALKOUT™ SMOKING SHELTER

TECHNICAL DATASHEET

ALUMINIUM | POLYCARBONATE | RECYCLED PLASTIC WOOD PLANKS

LENGTH: 2040mm (80.3")

WIDTH: 1200mm (47.25")

HEIGHT: 2280mm (89.75")

MOUNTING: Surface Anchor Bolts

FINISH: Anodized Aluminium

TECHNICAL DRAWING REFERENCE

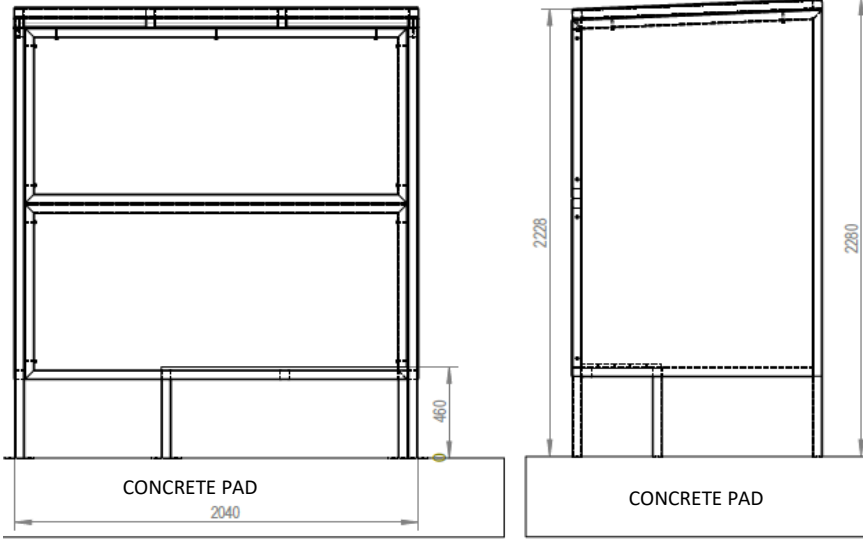

REAR VIEW

SIDE VIEW

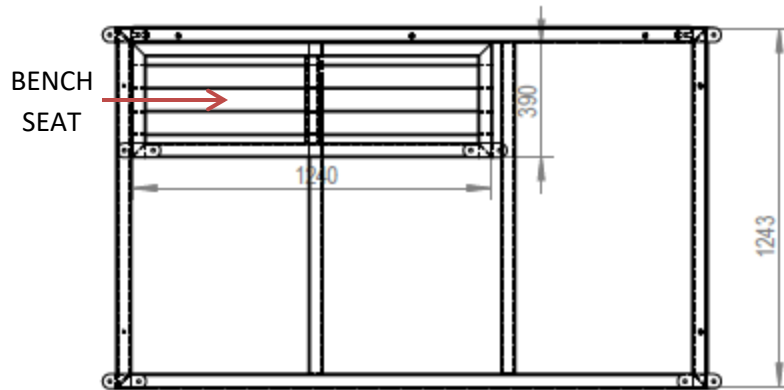

TOP VIEW



CIVIC
 ASH URN
 (placement
 option)

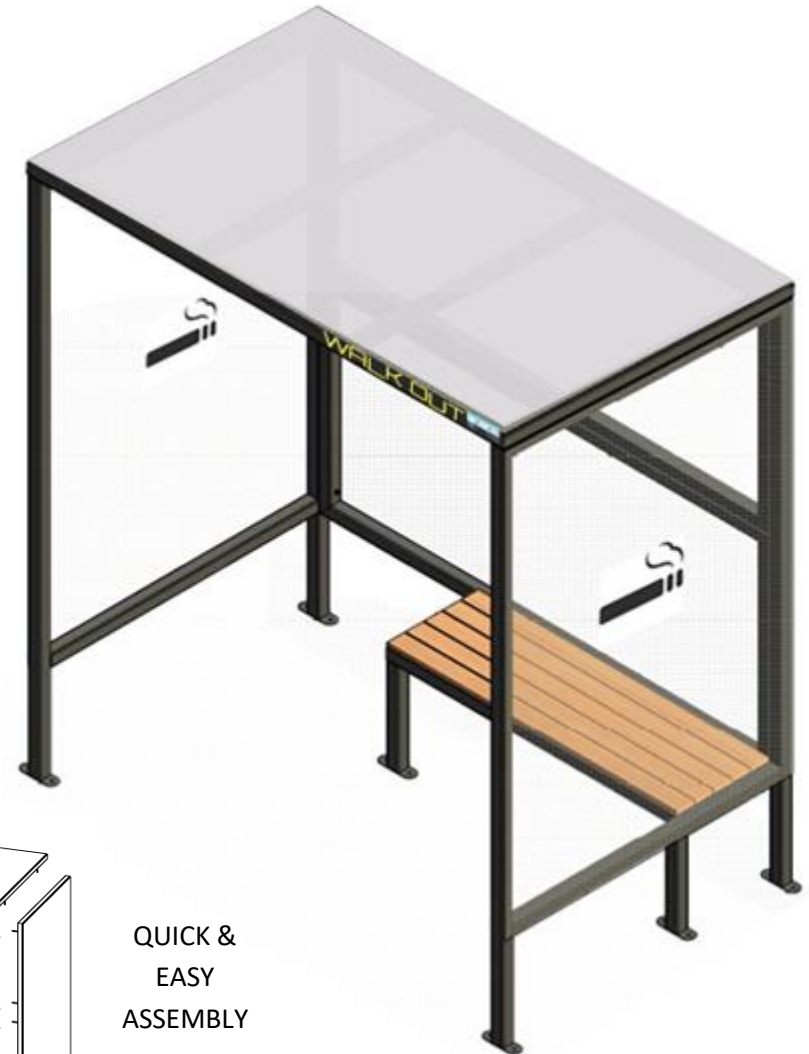

QUICK &
 EASY
 ASSEMBLY

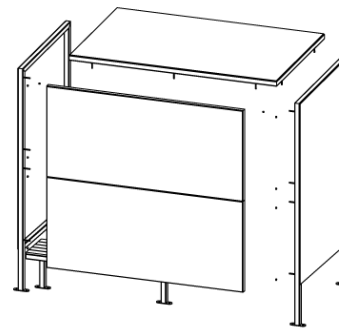

MATERIAL SPECIFICATIONS

50x50mm Aluminium frame construction, 4mm Polycarbonate side panels & roof,
 58mm width Recycled plastic seat planks, #304 Stainless steel hardware.

RAL Standard Colours:

**Final product design may not be exactly as shown.